

ARTICULO: 2114 / 2114D

Válvula de mariposa extremos ranurados con reductor manual Butterfly valve grooved ends with gear – box

Características

1. Válvula de mariposa extremos ranurados.
2. Construcción en fundición nodular EN-GJS-400 (GGG-40).
3. Disco de fundición nodular recubierto con EPDM.
4. Diseño según API 609.
5. Longitud entre caras según MSS SP-67.
6. Extremos ranurados según AWWA C606.
7. Recubrimiento interior y exterior con pintura Epoxy RAL 3000.
8. Reductor manual con finales de carrera internos.
9. Presión de trabajo 300 PSI.
10. Temperatura Máxima de trabajo: 80°C.
11. Certificación UL/FM para aplicación en instalaciones fijas contra incendios.

Features

1. Butterfly valve grooved ends.
2. Made by Ductile Iron EN-GJS-400 (GGG-40).
3. Butterfly disc of ductile iron coated EPDM.
4. Design according to API 609.
5. Face to Face according to MSS SP-67.
6. Grooved ends according to AWWA C606.
7. Inside & Outside with Epoxy coating RAL 3000.
8. Gear box with limit switches inside.
9. Working pressure 300 PSI.
10. Max. Working temperature 80°C.
11. UL/FM certification for use in fire protection systems.

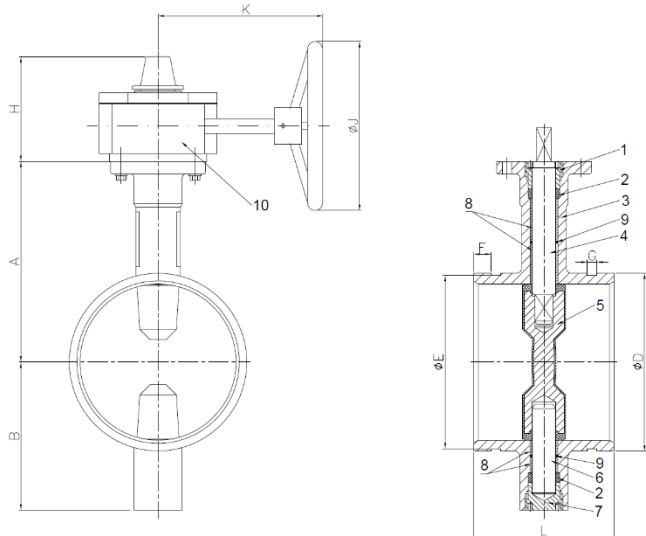

Nº	Denominación / Name	Material	Acabado Superficial / Surface Treatment
1	Tuerca eje superior / Upper shaft nut	Acero carbono / Carbon steel	-----
2	Reten eje / Shaft seal	EPDM	-----
3	Cuerpo / Body	Fund. nodular / Ductile Iron EN-GJS-400	Epoxy
4	Eje Superior / Upper shaft	Acero Inox. / Stainless Steel AISI 416	-----
5	Disco / Disc	Fund. nodular / Ductile Iron + EPDM	-----
6	Eje Inferior / lower shaft	Acero Inox. / Stainless Steel AISI 416	-----
7	Tuerca eje inferior / Lower shaft nut	Acero carbono / Carbon steel	-----
8	Casquillo eje / Stem bushing	PTFE	-----
9	Tórica / O'ring	EPDM	-----
10	Reductor manual / Gear Box	-----	Epoxy

DIMENSIONES GENERALES / GENERAL DIMENSIONS:

Ref	Medida Size	Dimensiones / Dimensions (mm)									
		L	D	E	F	G	A	B	H	K	J
2114 10	2 ½"	96.8	73 (*)	69.1	15.9	7.9	125	95	111	153	152
2114D 10	DN65		76.1 (**)	72.3							
2114 11	3"	96.8	88.9	84.9	15.9	7.9	140	100	111	153	152
2114 12	4"	115.8	114.3	110.1	15.9	9.5	160	100	111	153	152
2114 13	5"	147.6	141.3 (*)	137	15.9	9.5	170	125	111	153	152
2114D 13	DN125		139.7 (**)	135.5							
2114 14	6"	147.6	168.3 (*)	164	15.9	9.5	190	140	111	153	200
2114D 14	DN150		165.1 (**)	160.8							
2114 16	8"	133.4	219.1	214.4	19	11.1	230	175	126	210	300

(*) Para tubo / For Pipe: ASME B 36.10
(**) Para tubo / For Pipe: UNE-EN 10255

REDUCTOR MANUAL CON FF.CC / GEAR BOX WITH LIMIT SWITCHES:

