

## ARTICULO: 2943

### Válvula mariposa extremos para soldar DIN 11851, Inoxidable. Línea Sanitaria Stainless steel welding ends DIN 11851 butterfly valve. Sanitary line.

#### Características

1. Válvula mariposa línea sanitaria.
2. Extremos para soldar según DIN 11851.
3. Construcción en Inox AISI 316 L.
4. Elastómero de EPDM.
5. Accionamiento manual, tres posiciones.
6. Peso y dimensiones reducidas.
7. Fácil limpieza y montaje.
8. Fácil automatización.
9. Pulido Sanitario ( $Ra \leq 0,8 \mu m$ ).
10. Bajo torque.
11. Presión de trabajo máxima 10 Kg/cm<sup>2</sup>.
12. Temperatura máxima de trabajo 120 °C.

#### Features

1. Butterfly valve sanitary line.
2. Welding ends according to DIN 11851.
3. Made by AISI 316L.
4. EPDM seat.
5. Manual operation with three position.
6. Reduce weight and dimensions.
7. Easy cleaning and assembly.
8. Easy automation.
9. Sanitary Polish ( $Ra \leq 0,8 \mu m$ ).
10. Low torque.
11. Max. Working pressure 10 Kg/cm<sup>2</sup>.
12. Max. Working Temperature 120 °C.

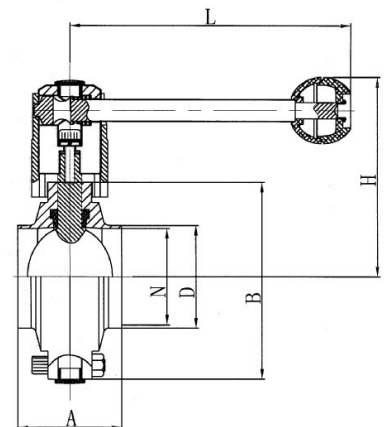
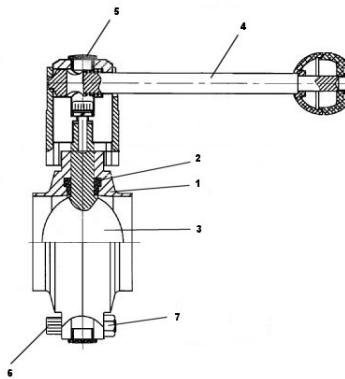

Nº	Denominación / Name	Material	Acabado Superficial/Surface Treatment
1	Cuerpo / Body	Acero Inox AISI 316L / SS 316L	Pulido mecánico / Mechanical Polish
2	Elastómero / Seat	EPDM	-----
3	Disco / Disc	Acero Inox AISI 316L / SS 316L	Pulido mecánico / Mechanical Polish
4	Maneta / Handle	Acero Inox AISI 316 / SS 316	-----
5	Tapa / Cap	Plastic	-----
6	Tornillo / Bolt	Acero Inox AISI 304 / SS 304	-----
7	Tuerca / Nut	Acero Inox AISI 304 / SS 304	-----

## DIMENSIONES GENERALES / GENERAL DIMENSIONS

Ref.	Medida/ Size	DN	Dimensiones/Dimensions (mm)						Peso / Weight (Kg.)
			A	B	D	N	H	L	
2943 06	1"	25	50	78	28	25	84	126	1,200
2943 07	1 ¼"	32	50	86	34	31	88	126	1,050
2943 08	1 ½"	40	50	90	40	37	90	126	1,200
2943 09	2"	50	52	106	52	49	101	133	1,700
2943 10	2 ½"	65	56	124	70	66	110	144	2,100
2943 11	3"	80	60	139	85	81	121	160	2,400
2943 12	4"	100	64	159	104	100	129	160	3,050

## DIAGRAMA DE PERDIDAS DE CARGA / HEAD LOSSES DIAGRAM

